



ORIGINAL ARTICLE

A novel ambulatory closed circuit breathing system for use during exercise

R. C. N. McMorrow,^{1,2} J. S. Windsor,^{3,4} M. G. Mythen,^{5,6} M. P. W. Grocott^{7,8} and the Caudwell Xtreme Everest Research Group*

1 Research Fellow, 3 Research Fellow, 5 Professor, 7 Senior Lecturer, UCL Centre for Altitude Space and Extreme Environment Medicine, UCL Institute of Child Health, University College London, London, UK

2 Consultant, Department of Anaesthesia, National Maternity Hospital & St Vincent's University Hospital, Dublin, Ireland

4 Specialist Registrar, Department of Anaesthesia, Barnet and Chase Farm Hospitals NHS Trust, Barnet, UK

6 Smiths Medical Professor of Anaesthesia and Critical Care, UCL/UCL Hospitals, National Institute of Health Research Comprehensive Biomedical Research Centre, London, UK

8 Consultant, Department of Critical Care, Southampton University Hospitals NHS Trust, Southampton, UK

Summary

We describe a unique ambulatory closed circuit for delivering high fractions of inspired oxygen to an exercising user who does not require isolation from their environment. We describe the major components and their function and suggest potential applications for such a circuit. This circuit may benefit patients who are chronically dependant on oxygen, are unable to exercise due to hypoxia, or require oxygen supplementation at high altitude.

Correspondence to: Dr R. C. N. McMorrow

Email: mcmorrow.roger@gmail.com

*The members of the Caudwell Xtreme Everest Research Group are listed in Appendix 1.

Accepted: 17 February 2011

Ambulatory closed circuits deliver high partial pressures of inspired oxygen (P_{iO_2}) from a limited oxygen source that is normally carried by the user. The circuits are heavier and more complex than the open, semi-open or semi-closed circuits described by Mapleson [1]. This is largely due to the addition of a carbon dioxide (CO_2) absorber, and the associated tubing and valves that are required to manage the flow of gases. The extra mass, and the possibility of delivering a hypoxic mixture during failure, have limited ambulatory closed circuits use. Such circuits are generally used by trained individuals, such as advanced divers, fire-fighters and specialised mine rescuers who have no option but to be isolated from their environment [2].

We describe below the components of, and rationale behind, the design of a novel ambulatory closed circuit, where the user does not have to be isolated from his/her environment. This may have applications for patients who are chronically dependent on oxygen, are

unable to exercise due to hypoxia, or require oxygen supplementation at high altitude.

Description of the closed circuit

The circuit plan is shown in Fig. 1 and a photograph of the prototype is shown in Fig. 2. The major components of the circuit are mounted on a back plate and harness. The circuit is comprised of: a user interface that includes the facemask; a CO_2 absorber and housing; a water trap; a reservoir limb; an oxygen source; and an electronic control unit. These components, that have a combined mass of approximately 10 kg, are described in detail below.

User interface/facemask

A T-shaped nasal and mouth two-way non-rebreathing facemask (Hans Rudolph Shawnee, KS, USA, Part Number 8932) is used. This is supplied with oxygen

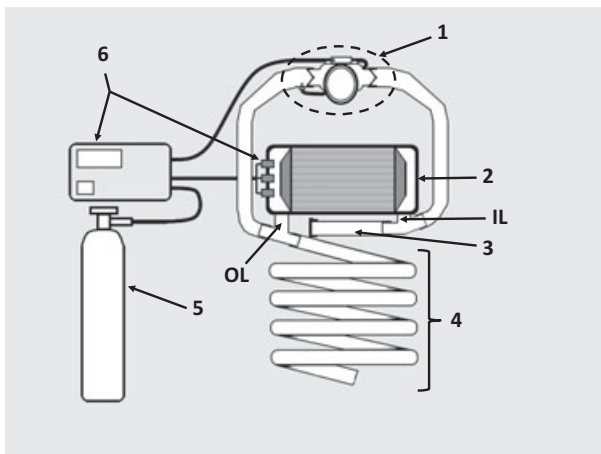

Figure 1 A circuit diagram for the breathing system: (1) user interface comprising mask, valves, two light-emitting diode (LED) indicators, a flow indicator, oxygen port and inspiratory and expiratory limbs; (2) CO₂ absorber and housing. Inlet (IL) and outlet (OL) ports are indicated; (3) expiratory limb water trap; (4) reservoir limb; (5) oxygen source; (6) electronic control, display and three oxygen sensors.

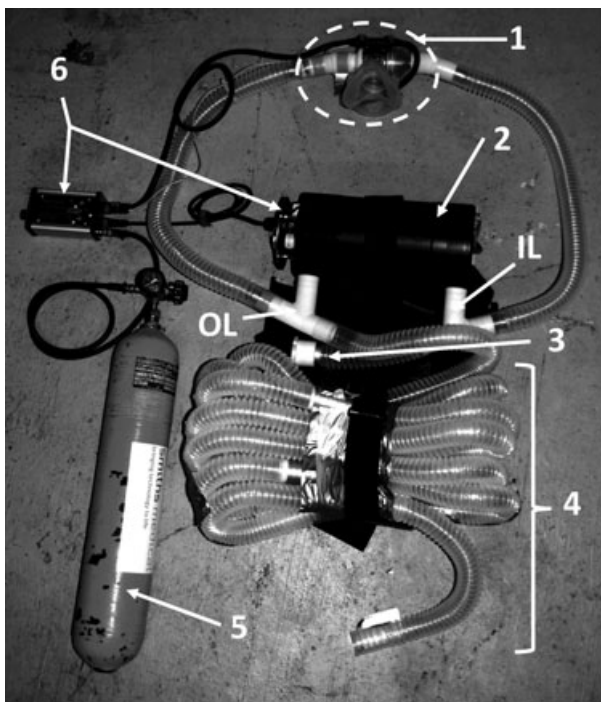

Figure 2 The prototype circuit highlighting the major components mounted on a back plate and harness: (1) user interface comprising mask, valves, two light-emitting diode (LED) indicators, a flow indicator, oxygen port and inspiratory and expiratory limbs; (2) CO₂ absorber and housing. Inlet (IL) and outlet (OL) ports are indicated; (3) expiratory limb water trap; (4) reservoir limb; (5) oxygen source; (6) electronic control, display and three oxygen sensors.

from one of two female Luer lock ports (Hans Rudolph Part Number 171179) positioned on the inspiratory port. A pair of 1-m long, internally smooth bore, 35-mm internal diameter polyvinyl chloride (PVC) externally corrugated tubes are connected to the facemask. These tubes serve as the inspiratory and expiratory limbs of the circuit.

Two light emitting diodes (LEDs), easily visible to the user, are mounted on the superior aspect of the facemask. These are connected to the electronic control unit to convey information about the status of the electronics and the current P_IO₂.

A mechanical flow sensor, comprised of a sprung bobbin held in a perspex cylinder, is also mounted on the superior aspect of the facemask (Poisk, St-Petersburg, Russia). It is connected in series with the oxygen tubing to indicate the presence or absence of the flow of oxygen to the mask. When oxygen flow is present the bobbin appears; however, when the supply ceases, the bobbin disappears.

CO₂ absorber and housing

A plastic housing made from Delrin (DuPont, Wilmington, DE, USA) was used to hold a non-granular ExtendAir™ CO₂ absorber (Micropore Inc., Newark, DE, USA) containing 2 kg of calcium hydroxide (CaOH) (Fig. 3). Two bespoke T-shaped connectors (CRDM Silicone sealed SLS Nylon-12) were used to connect the 35-mm inspiratory and



Figure 3 The Solid State ExtendAir™ calcium hydroxide CO₂ absorber. The inset shows the castellation channels incorporated to aid the flow of gas through the absorber.

expiratory limbs to the absorber outlet and inlet, respectively. The combined weight of the complete housing and absorber was 3.5 kg.

Water trap

A 30-cm long section of internally smooth bore, 35-mm internal diameter PVC externally corrugated tubing was capped with a removable plug and connected to the T-shaped absorber inlet connector to serve as a water trap.

Reservoir limb

This is comprised of six 1-m long sections, of internally smooth bore, 35-mm internal diameter PVC externally corrugated tubing, connected together in series with bespoke connectors (CRDM Silicone sealed SLS Nylon-12). This was designed to collect exhaled gases following CO₂ scrubbing and to provide gas for subsequent inspiration. It was connected at its proximal end to the T-shaped connector on the CO₂ absorber's expiratory port. Its distal end was open to, and in continuous fluid movement with, the atmosphere. The chosen reservoir volume is a compromise between having a sufficiently large volume with low resistance to flow and the practicalities of carrying sufficient tubing that doesn't generate excessive resistance to flow. Ideally, the reservoir limb should at least exceed the user's vital capacity so that all of their exhaled gas is always recovered. In this embodiment the reservoir limb's volume was approximately 6.25 l.

Oxygen source

A four-litre oxygen bottle was filled to 300 bar at 24 °C, and connected to a flow regulator and low-pressure hose to deliver oxygen to the facemask via the electronic control unit (Poisk). The cylinder, regulator and hose weighed approximately 2.5 kg.

Electronic control unit

A bespoke electronic control unit was designed specifically for the circuit (Owen Drumm, Dublin, Ireland). It was used to monitor, record and display the P₁O₂ in the circuit on a digital LED screen. Three oxygen sensors (Part Number PSR-11-39-MD; Analytical Industries Inc., Pomona, CA, USA) were mounted on the expiratory end cap of the CO₂ absorber housing. Three sensors were used to provide redundancy should one or two fail. A solenoid valve in the control unit was used to regulate the flow of oxygen. When powered, the valve closes, thus stopping the flow of oxygen to the facemask. Intermittent operation of this valve is used to restrict the flow of oxygen to the circuit to maintain the desired P₁O₂. Four AA lithium ion batteries powered the electronics. The mask mounted LEDs were used to indicate the status of the circuit to the user (Table 1).

Circuit operation

To operate the circuit, the flow from the oxygen source is first set to 3 l.min⁻¹. This value is assumed to be greater than a user's typical maximal oxygen

Table 1 Table outlining the implication of the facemask mounted light-emitting diodes (LEDs).

LED status	Indicating	Explanation
No light	No power/power failure/firmware fault	This indicates that the electronics have not been switched on, that the power has failed, or that the electronics have detected a firmware fault and switched themselves off. There will be no restriction to the flow of oxygen in this state
Flashing dim green	Normal operation	This indicates that the firmware is working correctly and that the P ₁ O ₂ is above the set value*
Solid bright green	Valve closed	The user may notice from the mechanical flow sensor that there is no oxygen flow. This indicates that this is a deliberate action by the electronics rather than a failure of oxygen flow for another reason
Flashing bright amber	P ₁ O ₂ lower than set value*	This indicates that there is an unknown problem in maintaining the P ₁ O ₂ at or above the set value*, or that atmospheric air has entered the circuit
Flashing bright red	P ₁ O ₂ is 20 kPa or less	This indicates that there is a problem with the delivery of oxygen to the circuit and the user should immediately convert the circuit to an open circuit or remove the facemask entirely until the problem is identified and corrected

*The set value is user definable.

consumption. Assuming a correct seal has been made with the facemask, the user is able to begin breathing from the circuit. The volume for the user's first breath from the circuit will come from the oxygen enriched air in the inspiratory limb. As this volume is removed from the inspiratory limb an exact matching volume of atmospheric air enters the reservoir limb to compensate for this volume change. If the oxygen sensors register a fall in $P_{I\text{O}_2}$ due to atmospheric air that enters the circuit, the electronic control unit will increase the flow of oxygen by allowing it to flow unrestricted into the circuit, until the $P_{I\text{O}_2}$ rises to the set value, again. As the user exhales, the CO_2 -laden, oxygen-enriched air travels down the expiratory limb and the volume of atmospheric air that was originally entrained is once again expelled. Carbon dioxide is absorbed on its first pass through the absorber. The next breath the user takes will be the scrubbed oxygen-enriched air with an appropriate portion of fresh oxygen added, determined by the electronic control unit. The user can never directly inhale the atmospheric air, as the inhaled volume comes from the exhaled scrubbed gas. By regulating the flow of oxygen in a closed loop fashion over time, the supply of oxygen will match the user's oxygen consumption plus the portion that will leak from the circuit.

When the minute volume is constant, atmospheric air will enter the distal end of the reservoir limb and oscillate in keeping with the user's tidal volume. As the reservoir limb is open to atmosphere, rapid changes in tidal volume can be easily accommodated and water is free to drain from the circuit.

Discussion

This circuit demonstrates a potential solution for users requiring a high $P_{I\text{O}_2}$ and minimal airway resistance, or for individuals who wish to rebreathe an additional gas such as helium or xenon. These performance characteristics are achieved by combining the classical circular, closed circuit, with the unique open reservoir limb that is in free fluid communication with the atmosphere.

There are a number of advantages to this open reservoir system which are as follows. The open limb allows for a large flux in tidal volume without the risk of the distressing sensation where the user attempts to inspire against a collapsed reservoir bag. The sensation is known as 'bottoming out' among ambulatory closed circuit users. In addition, an open limb minimises the expiratory resistance by allowing the user always to

exhale freely without the need for a pressure release valve. The open limb also allows nitrogen gas to exit the circuit as the $P_{I\text{O}_2}$ rises, without the user formally expelling it using high flows of oxygen before use. This is a practice that divers and fire-fighters must currently endure [3]. Conversely the open limb allows nitrogen to enter the circuit allowing the user to deliver a set $P_{I\text{O}_2}$ without the need to carry a second bottled buffer gas.

If the circuit is ever compromised by a breach or an undetected leak on the expiratory limb, the user will exhale proportionately more gas to the atmosphere and hence lose volume from the circuit. A compensatory volume of air automatically enters via the open limb, thereby preserving the volume in the circuit. If the leak is on the inspiratory limb, the user will entrain more atmospheric air. The circuit pressure will not rise as proportionately more gas is then expelled via the open reservoir. Any fall in $P_{I\text{O}_2}$ will be detected by the electronic control unit, which will increase the flow of oxygen to compensate. In essence, the circuit behaves more and more like an open circuit as an undetected leak increases. This failure mode ensures that without any user intervention the circuit automatically behaves as an open circuit, unlike classic closed circuits which require an operator to intervene either to compensate for the loss of volume with fresh gas or to fix the leak. The user may also convert the circuit to an open circuit by deliberately disconnecting the expiratory limb, ensuring no exhaled gas re-enters the circuit. The rigid reservoir also means that the user cannot accidentally mechanically collapse the reservoir. Finally, an open reservoir allows water to drain without accumulating.

The disadvantage of an open reservoir is that oxygen will inevitably be lost via the open limb. The rate of loss will be determined by the exact physical characteristics of the limb, the user's breathing pattern and the $P_{I\text{O}_2}$ that the user is trying to maintain within the circuit. The sensation of 'bottoming out', while unpleasant, is nevertheless a physical warning that is lost in the current system. If no oxygen flowed into this circuit and the user was unaware of or ignored the low oxygen warnings, they would be able to breathe a potentially lethal hypoxic mixture. While positive end-expiratory pressure may be added easily, this circuit is not suitable for positive pressure ventilation.

During exercise, individuals increase both their minute volume and oxygen demand. If they are using an open circuit with a fixed flow of oxygen, their $P_{I\text{O}_2}$ will fall proportionately with the increase in minute

volume due to the dilutional effect of atmospheric air. This has a paradoxical effect; as the user's demand for oxygen increases, their inspired P_{iO_2} actually falls [4].

By regulating the P_{iO_2} , this circuit demonstrates a closed loop system whereby oxygen delivery is matched to the user's demand for oxygen. This has the dual effect of conserving a limited oxygen supply and delivering an effective amount of oxygen during exercise. Similar closed loop control of oxygen delivery is described by Johannigman et al. [5]. We opted for a solid state ExtendAir™ CO_2 absorber due to its predictable performance, low resistance to air flow and the lack of a requirement for dust filters [6]. Unlike granules, this absorber doesn't shift with position, which can cause channelling and early absorber failure, nor does it produce dust, which despite filters is known to cause lung injury to closed circuit users [7, 8]. This circuit combines the advantages of classic ambulatory closed circuits (particularly that of oxygen conservation by using low flows to maintain a high P_{iO_2}) with a design that can accommodate easily the high minute volumes and flux in those volumes that are found during exercise.

There are a number of non-diving-related portable closed circuit systems commercially available, such as the BioPak (BioMarime, Exton, PA, USA). While this system is used by professional law enforcement, military, fire and underground rescue services, it has also been used successfully on a caving expedition to Northern Thailand where the atmosphere was intolerable to humans due to microbial activity's raising the CO_2 concentration to over 5% [9]. This system is, however, fully closed and its performance characteristics during exercise are not published. The North American Diver Alert Network (<http://www.divers-alertnetwork.org>) manufactured a surface Remote Emergency Medical Oxygen (REMO™; DAN, Durham, NC, USA) system that was a portable rebreather designed to help nitrogen washout during an emergency. It demonstrated excellent conservation of oxygen supply while maintaining a high P_{iO_2} . The system had problems with leakage of nitrogen into the system and it was not tested with high minute volumes [6]. Interestingly, both systems also opted to use the ExtendAir solid state CO_2 absorber.

Patients who are critically dependant on oxygen, such as those with acute or chronic cardiorespiratory conditions, or healthy individuals requiring oxygen supplementation at high altitude, may benefit from a circuit that matches their demand for oxygen with an adequate oxygen supply in a system that has highly

desirable breathing characteristics. This may enable individuals to exercise where hypoxaemia would otherwise be a limiting factor with respect to exercise capacity.

This circuit may also be useful for the delivery and recovery of expensive gases such as helium and xenon that would otherwise be lost to the atmosphere. Reducing inspired gas density has been shown to double endurance time for constant work rate ergometer exercise tests in chronic obstructive airway patients [10, 11].

Empirical measurement of the actual circuit performance with regard to heat production and loss by the user and CO_2 absorber, water management, breathing resistances during typical peak flows, and the characteristics of the ideal design of the reservoir limb, have yet to be determined. Oxygen will inevitably leak via the reservoir but the rates have yet to be established.

This novel closed circuit may provide advantages in the ambulatory delivery of oxygen-enriched air or for the recovery of expensive gases for an exercising user. Trials in the laboratory setting are being undertaken and are planned in healthy volunteers; the results will be made public in due course.

Acknowledgements

This project was supported by Mr John Caudwell, BOC Medical (now part of Linde Gas Therapeutics), Eli Lilly, the London Clinic, Smiths Medical, Micropore Inc, Analytical Industries Inc, Deltex Medical, and the Rolex Foundation (unrestricted grants), the Association of Anaesthetists of Great Britain and Ireland, the United Kingdom Intensive Care Foundation, and the Sir Halley Stewart Trust. Some of this work was undertaken at University College London Hospital–University College London Comprehensive Biomedical Research Centre, which received a proportion of funding from the United Kingdom Department of Health's National Institute for Health Research Biomedical Research Centres funding scheme. Caudwell Xtreme Everest is a research project coordinated by the Centre for Altitude, Space, and Extreme Environment Medicine, University College London. Membership, roles, and responsibilities of the Caudwell Xtreme Everest Research Group can be found at <http://www.caudwell-xtreme-everest.co.uk/team>.

Competing interests

RCNM holds a patent on the new circuit design.

References

- 1 Mapleson WW. The elimination of rebreathing in various semi-closed anaesthetic systems. *British Journal of Anaesthesia* 1954; **26**: 323–32.
- 2 Guide N. *Guide for the Selection of Personal Protective Equipment for Emergency First Responders*, 2002; <http://www.ncjrs.gov/pdffiles1/nij/191521.pdf> (accessed 18/10/2010).
- 3 Neubauer B, Zander R, Tetzlaff K. Mathematical model for the calculation of oxygen concentrations in a closed circuit oxygen rebreathing apparatus. *Aviation Space and Environmental Medicine* 1997; **68**: 722–5.
- 4 Bateman N, Leach R. ABC of oxygen: acute oxygen therapy. *British Medical Journal* 1998; **317**: 798–801.
- 5 Johannigman J, Branson RD, Muskat P, et al. Closed loop control of oxygenation and ventilation. *Journal of Gravitational Physiology* 2007; **14**: P35–8.
- 6 Pollock NW, Natoli MJ. Performance characteristics of the second-generation remote emergency medical oxygen closed-circuit rebreather. *Wilderness and Environmental Medicine* 2007; **18**: 86–94.
- 7 Stoelting RK, Miller RD. *Basics of Anesthesia*, 5th edn, New York: Churchill Livingstone. 2007: 697
- 8 Neubauer B, Mutzbauer TS, Tetzlaff K. Exposure to soda-lime dust in closed and semi-closed diving apparatus. *Aviation Space and Environmental Medicine* 2000; **71**: 1248–51.
- 9 Smith S, Telling J. UBSS Expedition to northern Thailand 2003: breaking the Bad Air Barrier. *Proceedings University of Bristol Speleological Society* 2004; **23**: 87–95.
- 10 Casaburi R, Porszasz J. Reduction of hyperinflation by pharmacologic and other interventions. *Proceedings of the American Thoracic Society* 2006; **3**: 185–9.
- 11 Laude EA, Duffy NC, Baveystock C, et al. The effect of helium and oxygen on exercise performance in chronic obstructive pulmonary disease: a randomized crossover trial. *American Journal of Respiratory and Critical Care Medicine* 2006; **173**: 865–70.

Appendix 1: Membership of the Caudwell Xtreme Everest Research Group

Investigators: V. Ahuja, G. Aref-Adib, R. Burnham, A. Chisholm, K. Clarke, D. Coates, M. Coates, D. Cook, M. Cox, S. Dhillon, C. Dougall, P. Doyle, P. Duncan, M. Edsell, L. Edwards, L. Evans, P. Gardiner, M. Grocott, P. Gunning, N. Hart, J. Harrington, J. Harvey, C. Holloway, D. Howard, D. Hurlbut, C. Imray, C. Ince, M. Jonas, J. van der Kaaij, M. Khosravi, N. Kolfschoten, D. Levett, H. Luery, A. Luks, D. Martin, R. McMorrow, P. Meale, K. Mitchell, H. Montgomery, G. Morgan, J. Morgan, A. Murray, M. Mythen, S. Newman, M. O'Dwyer, J. Pate, T. Plant, M. Pun, P. Richards, A. Richardson, G. Rodway, J. Simpson, C. Stroud, M. Stroud, J. Stygal, B. Symons, P. Szawarski, A. Van Tulleken, C. Van Tulleken, A. Vercueil, L. Wandrag, M. Wilson, J. Windsor.

Scientific Advisory Group: B. Basnyat, C. Clarke, T. Horn-Bein, J. Milledge, J. West.